

**Dd**

**D**

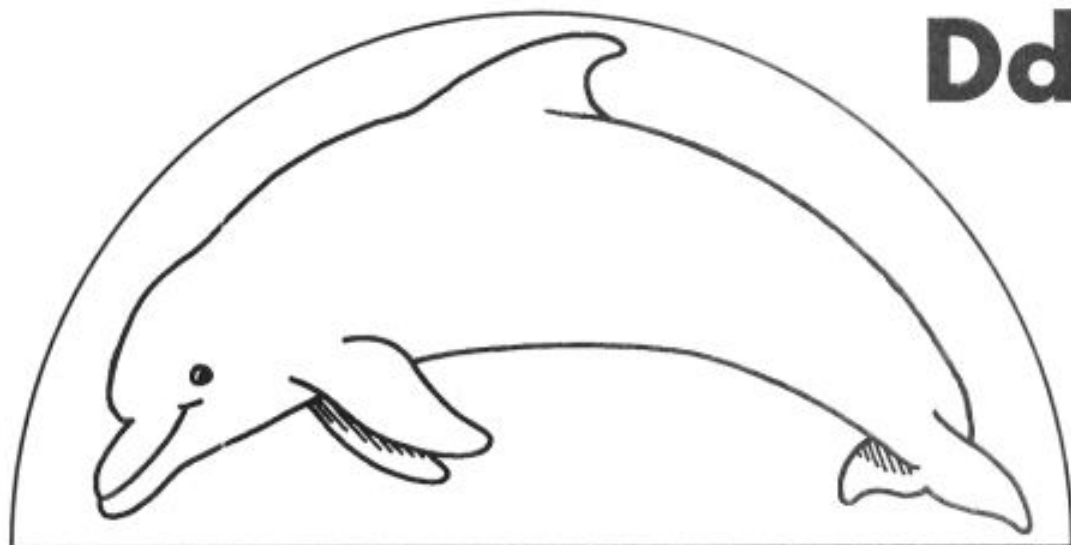

**D**

dolphin

**D**

dog



**D**

dentist



doll



**d**

dish



**d**

diamond

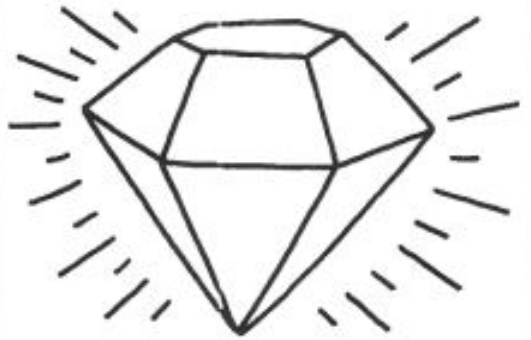

**d**

duck

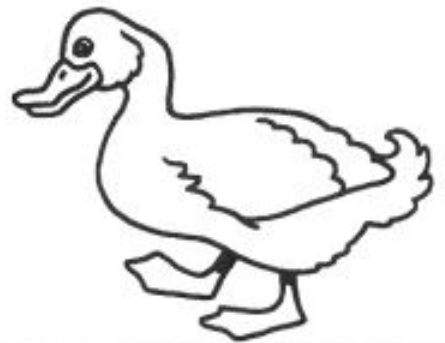

**d**

bison

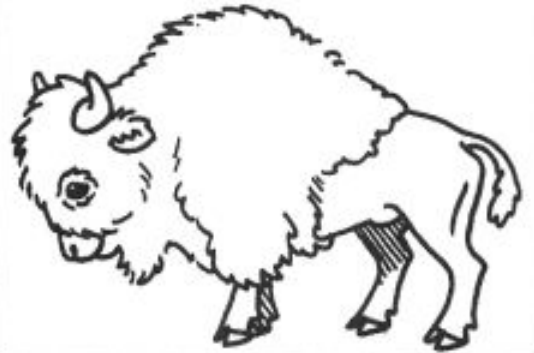

**d**

flag



## Table of Contents, Paper Plate Phonics - Beginning Sounds

Instructions and Activities.....	4
Alphabet a to z - vowels are short .....	7
Long vowel sounds .....	59
Soft g and soft c.....	69
Wh.....	73
Sh.....	75
Th.....	77
Ch.....	79
Ph.....	81
Kn.....	83
Cl.....	87
Tr.....	89
Dr.....	91
Blank grid for Bingo.....	93
Blank grid for Lotto.....	94
Blank grid for teachers or children to make their own pockets.....	95





7. Staple the second half of the paper plate to the lower half of the whole paper plate. Staple the rims facing the same direction to make a snug pocket.
8. Option: Glue one of the letter squares to the back snug pocket and draw a red X through the letter.

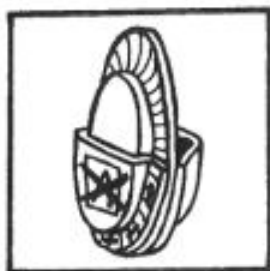

### Activity:

The child sorts the word/picture rectangles and letter squares that match the beginning sound into the roomy pocket in front. The cards that do not match are placed in the snug pocket in back.

*Challenge: After having made several pockets, some of the cards that were in the snug pockets can now be put in the roomy pocket with the correct sound.*

*Challenge: Give a child several pockets with similar looking letters and let him sort the cards into the correct pocket.*

*Example; let them sort g, p, and q.*

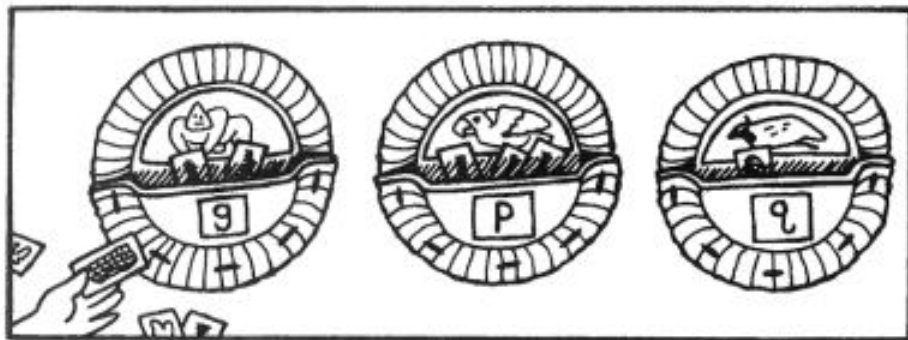

\* Use the blank grids on pages 93 and 94 to let the children add words and pictures of their own to one of the beginning sounds in the book or to add new beginning sounds like fl or br.

### Extended Activities

**Make a picture dictionary:** Provide 26 sheets of paper stapled along the left side, like a book. The child prints a letter of the alphabet at the top of each page. After all the sorting pockets have been made and used for practice, the picture/word rectangles can be glued onto the appropriate page in the book.

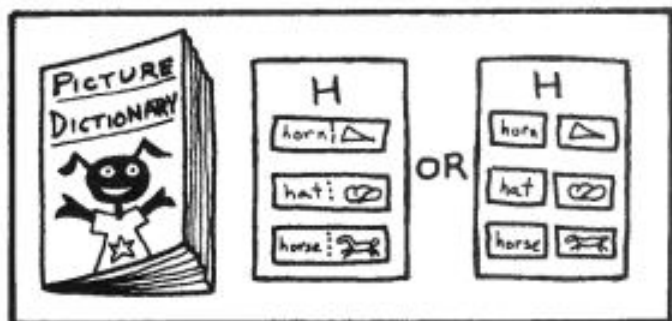



**Flash Cards:** Laminated picture/word cards can be used for the flash card games at a language center.

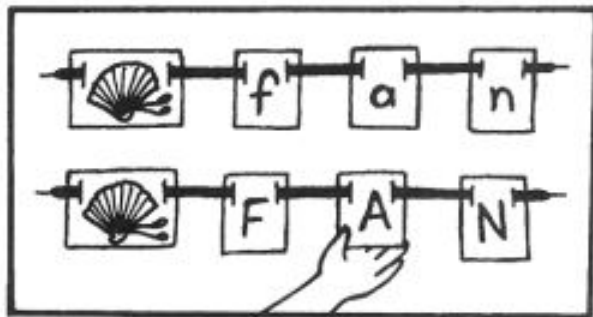

**Lace-A-Word:** Laminate a set of the letter squares and punch holes in the right and left side of each square. String a picture and letters to make a word on a shoelace as shown. Let the child string the word using upper case letters. *Options:* Let the child string the letters of his name or make new words and draw his own picture.

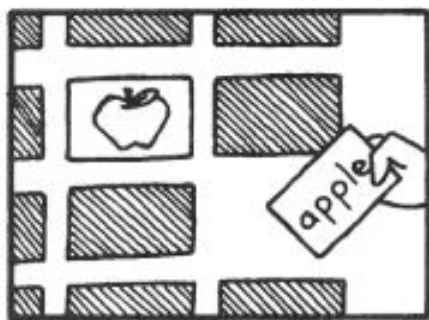

**Memory:** Laminate a set of picture/word cards. Cut the cards in half separating words and pictures. Use the cards to play memory, matching picture to word.

**Lotto:** Use the blank lotto grid on page 96 to make sets of lotto cards using combinations of the word, picture and letter cards.

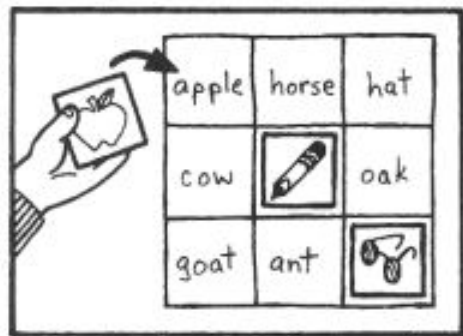
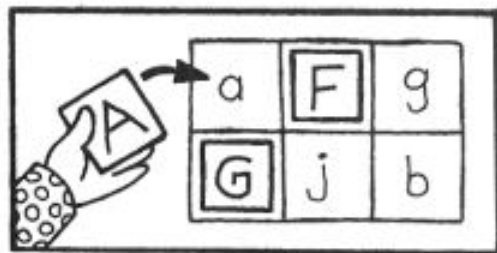

**Bingo:** Use the blank bingo grid on page 95 to make sets of bingo cards using combinations of the word, picture and letter cards.

**Bulletin Board Crossword Puzzle:** The teacher puts up the first word in a horizontal position in the middle of the bulletin board. Use a long word to get started. List the children's

names alphabetically on the far left side of the board. Assign points for each letter (1 to 26-A to Z is the easiest). The children use their letter squares to add words to the puzzle and keep score next to their name. This can be an ongoing activity during several weeks then change the starting word. Children can add their words during reading or spelling or in those three or four minutes while waiting for recess or lunch.

